



**Governor's Office of
Storm Recovery**

**KATHY
HOCHUL**

Governor

ADDENDUM # 2

GOSR-IFB-2022-01 – Storm Hardening at Edgewater Park Volunteer Fire Department

To: Potential Bidders
From: Governor's Office of Storm Recovery ("GOSR")
Date: June 28, 2022
Subject: Addendum # 2 – GOSR-IFB-2022-01 – Storm Hardening at Edgewater Park Volunteer Fire Department
Questions Due Date: July 1st 2022 no later than 2:00 pm EDT
Bid Due Date: July 13th 2022 no later than 2:00 pm EDT

NOTICE TO CONTRACTORS: This Addendum shall form a part of the Contract and clarifies, corrects, or modifies the original Invitation for Bid documents prepared by GOSR. This addendum must be signed and returned with the Bid.

MODIFICATIONS TO INVITATION FOR BID

The following are official modifications which are hereby incorporated into GOSR-IFB-2022-01 for Storm Hardening at Edgewater Park Volunteer Fire Department. The information contained in this Addendum prevails over the original IFB language and prior Addendums for all modifications below.

1. **INSERT** the below attachment(s), included with this Addendum #2, in the GOSR-IFB-2022-01 – Storm Hardening at Edgewater Park Volunteer Fire Department solicitation package after page 608:
 - o **Attachment 1 – Fire Alarm Plans**

All other terms and conditions in the Invitation for Bids remain unchanged.

If submitting a Bid, this Addendum # 2 for GOSR-IFB-2022-01 must be signed, dated, attached to, and made a part of your Bid.

Name of Company: _____

Authorized Signature: _____

Print Name and Title: _____

Date: _____

Address: _____

City, State, Zip Code: _____

Telephone Number: _____

Email Address: _____

Attachment 1 – Fire Alarm Plans

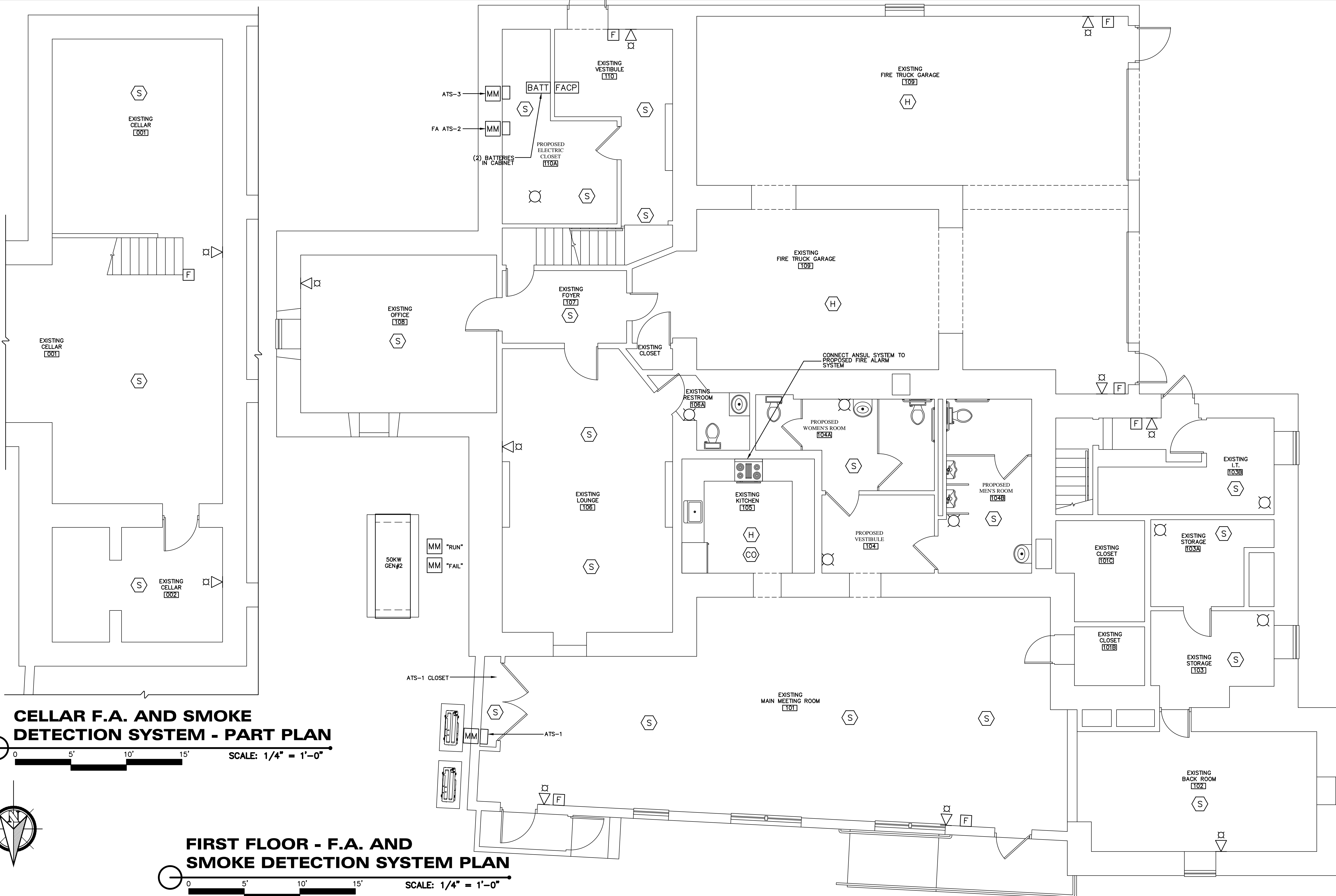

CELLAR F.A. AND SMOKE DETECTION SYSTEM - PART PLAN

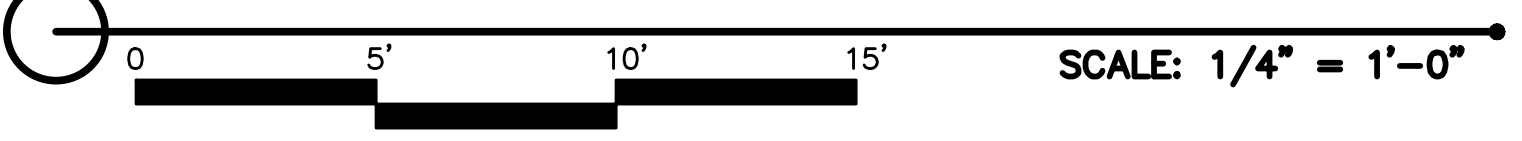

FIRST FLOOR - F.A. AND SMOKE DETECTION SYSTEM PLAN



D.O.B. APPROVAL STAMPS

ALL DIMENSIONS ARE TO BE FIELD VERIFIED

All Drawings, Specifications and the design expressed therein are the sole property of Mark Anthony Assoc., Inc. They are to be used only with respect to this Project and are not to be copied or reproduced without written permission of Mark Anthony Assoc.

- ISSUED FOR:
- PRELIMINARY DRAWING
 - FOR OWNERS REVIEW
 - FOR BIDDING PURPOSES
 - FOR BUILDING DEPT.
 - FOR CONSTRUCTION
 - AS BUILT DRAWINGS

REVISIONS			PLOTTED: 5/19/2022
NO.	DATE	DESCRIPTION	

PROJECT NO. 2022073

DATE 5/5/2022

SCALE AS NOTED

DRAWN BY M.A.M.



FIRE ALARM

DRAWING: **CELLAR & FIRST FLOOR FIRE ALARM PLAN**

PROJECT: **EDGEWATER PARK VOLUNTEER FIRE DEPARTMENT**

1 ADEE DRIVE
EDGEWATER PARK, NY 10465

D.O.B. I.D.#

DRAWING No. **FA-002.00**

4 OF 7

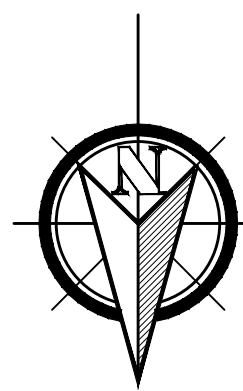
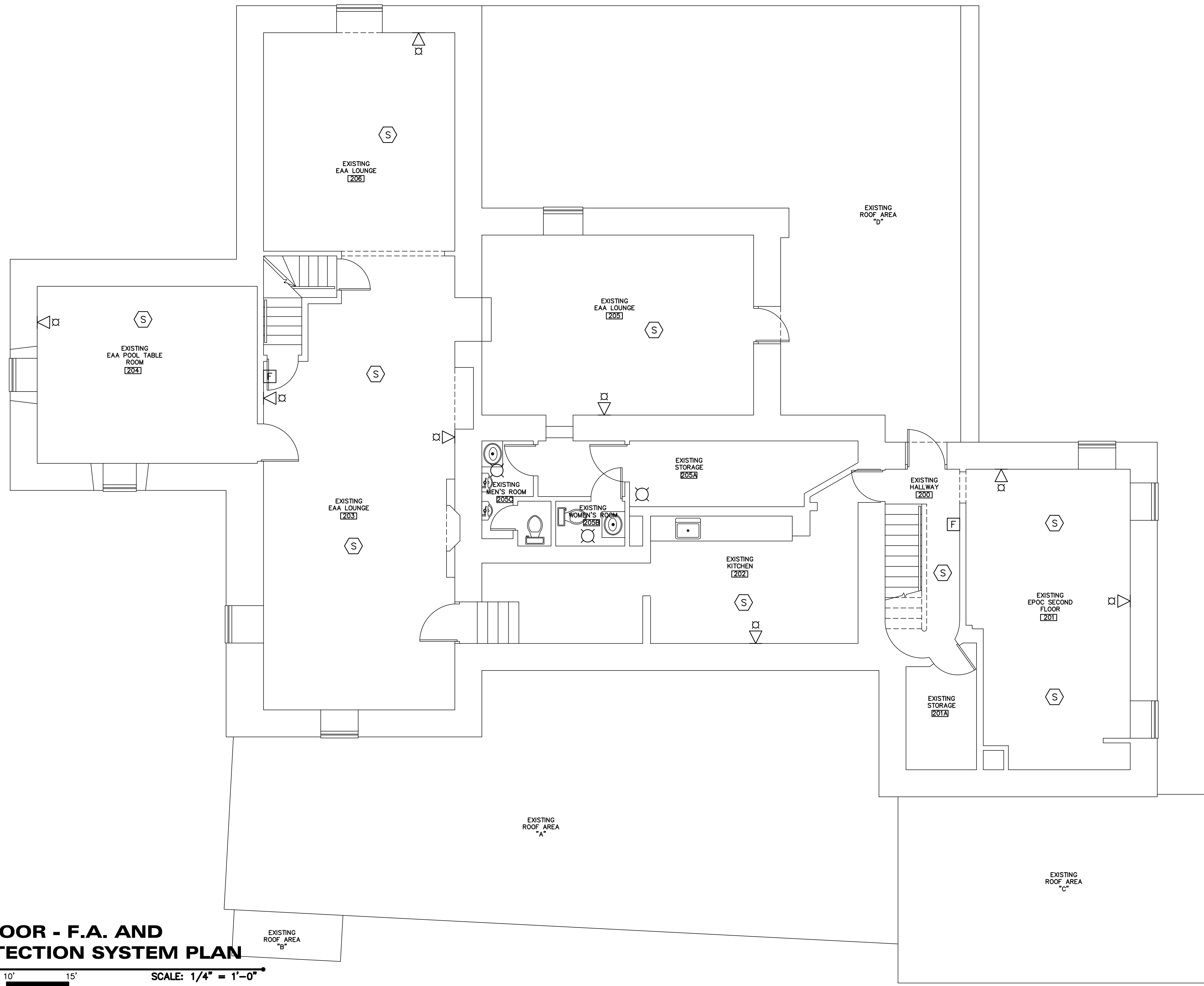

SECOND FLOOR - F.A. AND SMOKE DETECTION SYSTEM PLAN



D.O.B. APPROVAL STAMPS

ALL DIMENSIONS ARE TO BE FIELD VERIFIED

All Drawings, Specifications and the design expressed therein are the sole property of Mark Anthony Assoc., Inc. They are to be used only with respect to this Project and are not to be copied or reproduced without written permission of Mark Anthony Assoc.

- ISSUED FOR:
- PRELIMINARY DRAWING FOR OWNERS REVIEW
 - FOR BIDDING PURPOSES
 - FOR BUILDING DEPT. FOR CONSTRUCTION
 - AS BUILT DRAWINGS

REVISIONS			PLOTTED: 5/19/2022
NO.	DATE	DESCRIPTION	

PROJECT NO.	2022073
DATE	5/5/2022
SCALE	AS NOTED
DRAWN BY	M.A.M.



FIRE ALARM
DRAWING:
SECOND FLOOR FIRE ALARM PLAN

PROJECT:
EDGEWATER PARK VOLUNTEER FIRE DEPARTMENT
1 ADEE DRIVE
EDGEWATER PARK, NY 10465

D.O.B. I.D.#
DRAWING No.
FA-003.00
5 OF 7

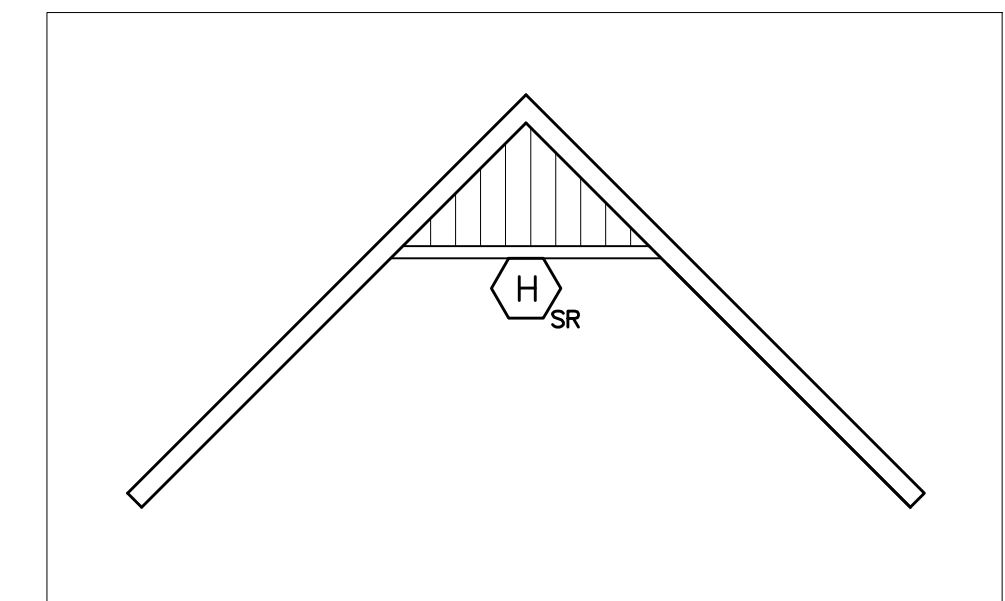
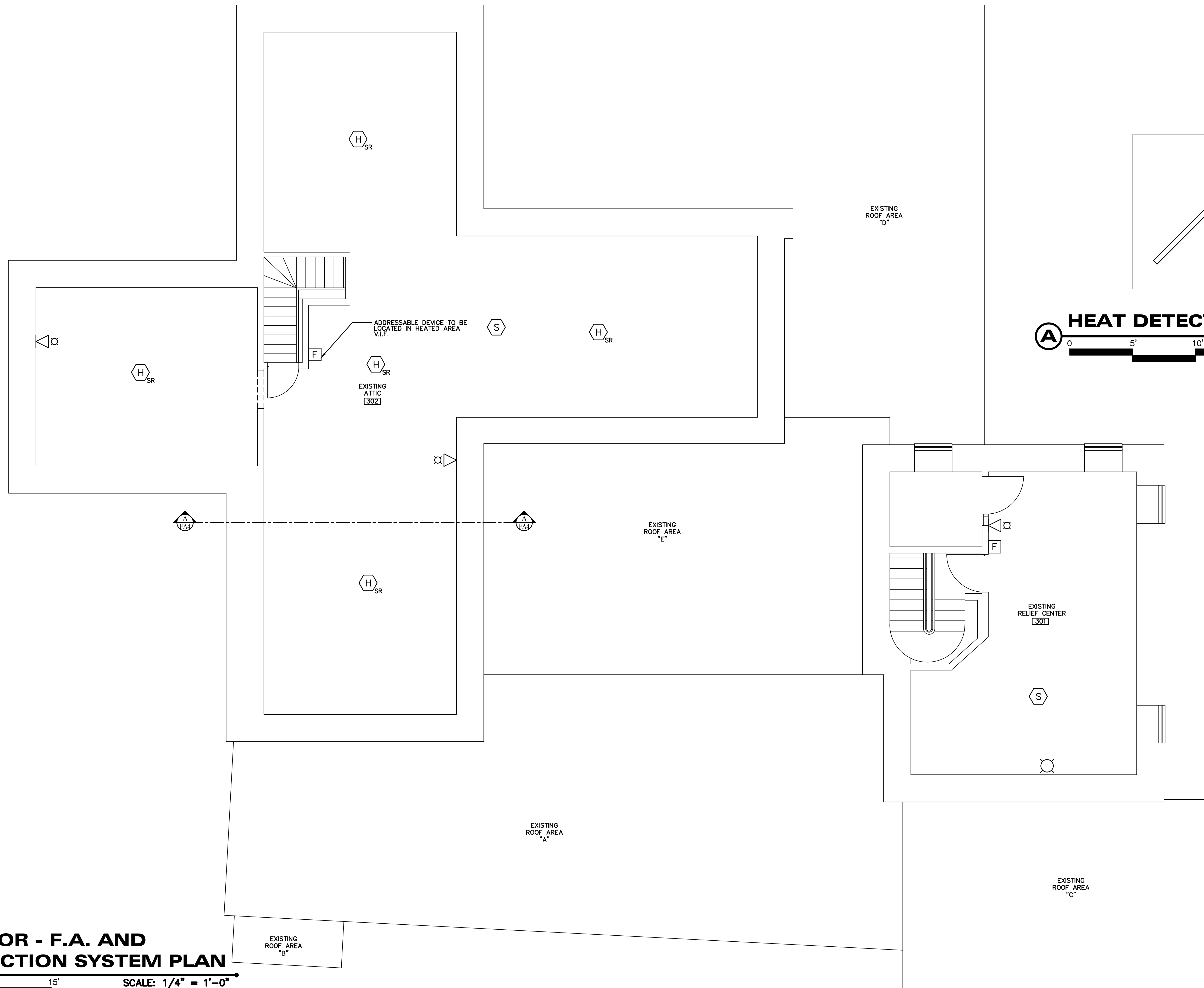

HEAT DETECTOR LOCATION IN ATTIC
 0 5' 10' 15' SCALE: 1/4" = 1'-0"

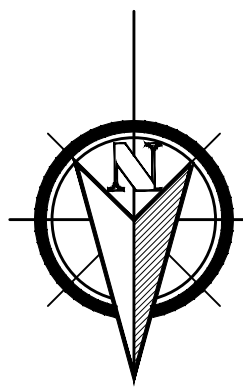

SECOND FLOOR - F.A. AND SMOKE DETECTION SYSTEM PLAN

0 5' 10' 15' SCALE: 1/4" = 1'-0"

D.O.B. APPROVAL STAMPS

ALL DIMENSIONS ARE TO BE FIELD VERIFIED

All Drawings, Specifications and the design expressed therein are the sole property of Mark Anthony Assoc., Inc. They are to be used only with respect to this Project and are not to be copied or reproduced without written permission of Mark Anthony Assoc.

- ISSUED FOR:
- PRELIMINARY DRAWING FOR OWNERS REVIEW
 - FOR BIDDING PURPOSES
 - FOR BUILDING DEPT.
 - FOR CONSTRUCTION
 - AS BUILT DRAWINGS

REVISIONS			PLOTTED: 5/19/2022
NO.	DATE	DESCRIPTION	

PROJECT NO.	2022073
DATE	5/5/2022
SCALE	AS NOTED
DRAWN BY	M.A.M.

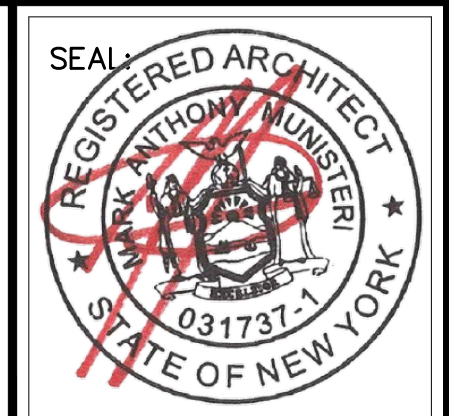

FIRE ALARM
 DRAWING:
THIRD FLOOR FIRE ALARM PLAN

PROJECT:
EDGEWATER PARK VOLUNTEER FIRE DEPARTMENT
 1 ADEE DRIVE
 EDGEWATER PARK, NY 10465

D.O.B. I.D.#
 DRAWING No.
FA-004.00
6 OF 7

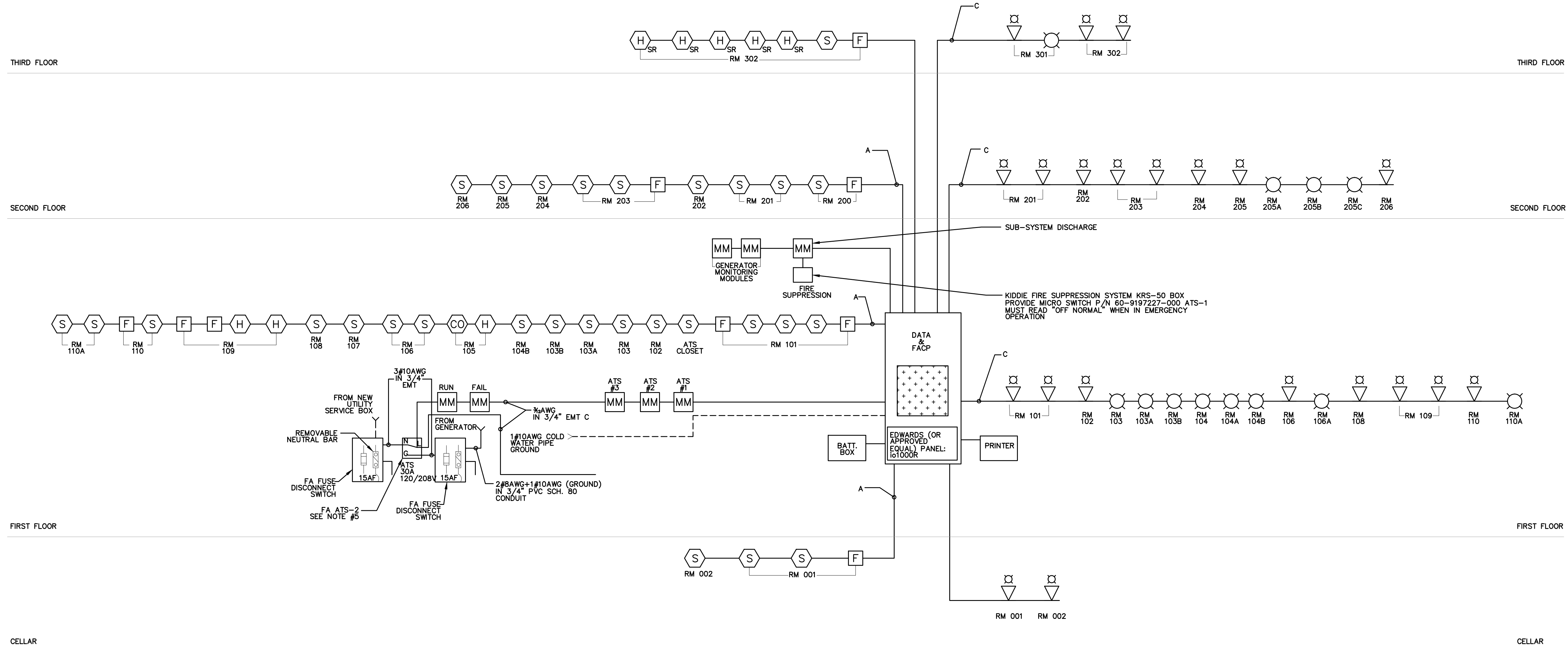

D.O.B. APPROVAL STAMPS

ALL DIMENSIONS ARE TO BE FIELD VERIFIED

All Drawings, Specifications and the design expressed therein are the sole property of Mark Anthony Assoc., Inc. They are to be used only with respect to this Project and are not to be copied or reproduced without written permission of Mark Anthony Assoc.

ISSUED FOR:

- PRELIMINARY DRAWING FOR OWNERS REVIEW
- FOR BIDDING PURPOSES
- FOR BUILDING DEPT.
- FOR CONSTRUCTION
- AS BUILT DRAWINGS

REVISIONS

NO.	DATE	DESCRIPTION

PLOTTED: 5/19/2022

PROJECT NO.	2022073
DATE	5/5/2022
SCALE	AS NOTED
DRAWN BY	M.A.M.



FIRE ALARM

DRAWING:

FIRE ALARM RISER DIAGRAM

PROJECT:

EDGEWATER PARK VOLUNTEER FIRE DEPARTMENT

1 ADEE DRIVE
EDGEWATER PARK, NY 10465

D.O.B. I.D.#

DRAWING No.

FA-005.00

7 OF 7